

King - Where Quality Counts

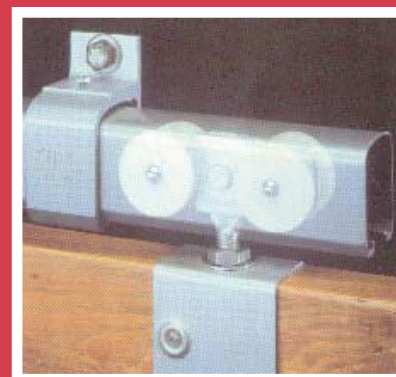

STRAIGHT SLIDING DOOR GEAR SELECTION AND SPECIFIER GUIDE

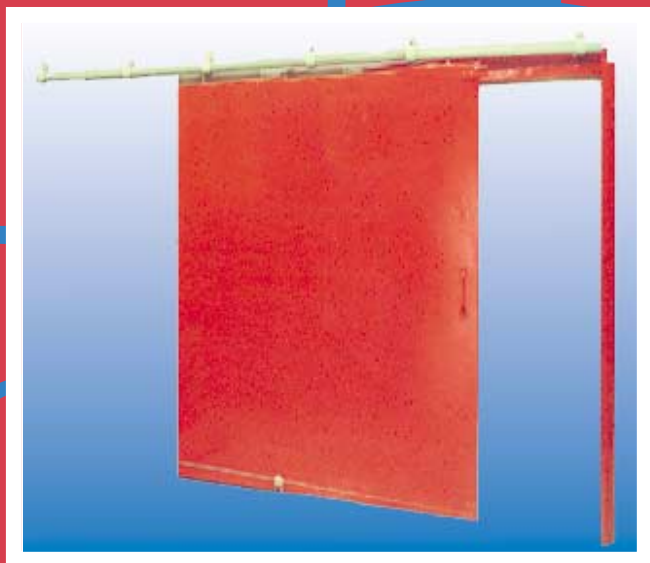

King - Where Quality Counts

CONTENTS

SECTION 1
TYPICAL APPLICATIONS AND
DOOR GEAR CONFIGURATIONS

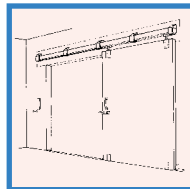

SECTION 2
TRACK

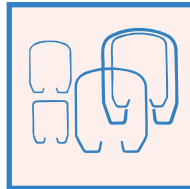

SECTION 3
BRACKETS

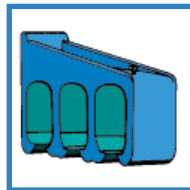

SECTION 4
HANGERS

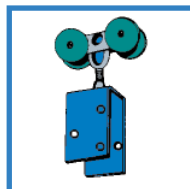

SECTION 5
GUIDES

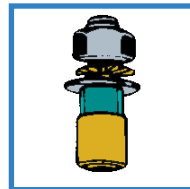

SECTION 6
CHANNEL

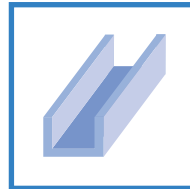

SECTION 7
DOOR FURNITURE

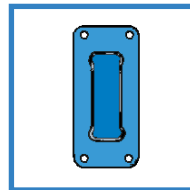

SECTION 8
EUROGEAR - A COMPACT
ALTERNATIVE



SECTION 9
ROYALE LIGHTWEIGHT
DOOR GEAR

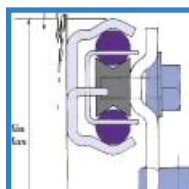

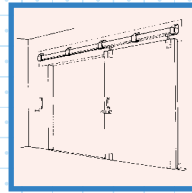

STRAIGHT SLIDING TIMBER & STEEL DOORS

TIMBER DOORS

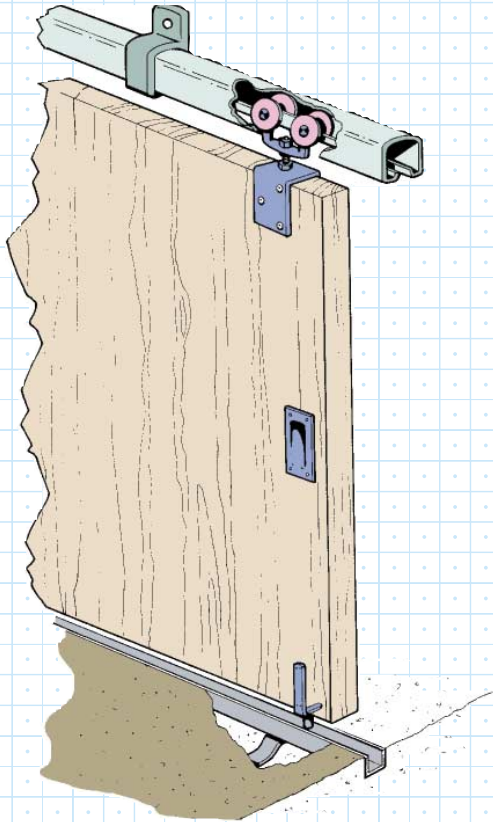

STEEL DOORS

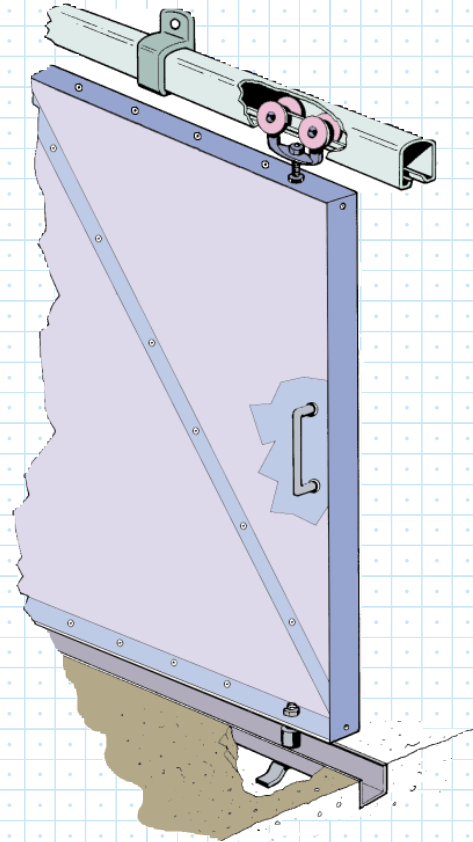

MAKING THE RIGHT CHOICE FOR YOUR DOOR

Before selecting King Sliding Door Gear determine the following :

- 1 PURPOSE OF BUILDING AND FLOOR CONSTRUCTION, .
- 2 INTERNAL OR EXTERNAL APPLICATION, TOP FIXING OR FACE FIXING.
- 3 CLEAR OPENING DIMENSIONS.
- 4 NUMBER AND THICKNESS OF DOOR LEAVES.
- 5 DOOR LEAF CONSTRUCTION - TIMBER OR STEEL.
- 6 WEIGHT OF EACH DOOR LEAF.

SELECTING TRACK SIZE

This is determined by the weight and / or height of the door, and the following guidelines should be observed :

ASSESSING THE WEIGHT OF A DOOR

A. **TIMBER** - typical softwood doors of framed, ledged and braced construction, filled with 16mm tongued, grooved and vee-jointed match board weigh approximately :

50mm Nom. Thickness = 22kgsqm

64mm Nom. Thickness = 25kgsqm

76mm Nom. Thickness = 29kgsqm

B. **METAL** - Due to large variety of materials and construction method weight should be determined by exact calculation.

ASSESSING THE SIZE OF A DOOR

a. **JAMBS** should be overlapped by 50mm to 76mm

b. **LINTELS** should be overlapped by 25mm to 40mm

c. **GROUND CLEARANCE** should be 10mm

d. **PASSING DOORS** should overlap by 64mm

TRACK SIZE

0
1
2
3
4

LOAD CAPACITY PER LEAF (kg)

115
200
454
700
1270

RECOMMENDED MAX. DOOR HEIGHT (mm)

2700
3300
4900
5500
6100

TYPICAL CONFIGURATION



Single door sliding on a single line of track

Overall door width	Track lengths mm	*Brackets	Hangers	Guides	Channel mm
1500	1x3000	5	2	2	3000
1800	2x1800	5	2	2	3600
2100	2x2100	7	2	2	4200
2400	2x2400	7	2	2	4800
2700	3x1800	7	2	2	5400
3000	2x3000	9	2	2	6000
3300	2x2400 1x1800	9	2	2	6600

Two doors sliding on a single line of track

Overall door width (both)	Track lengths mm	*Brackets	Hangers	Guides	Channel mm
2400	2x2400	7	4	4	4800
2700	3x1800	7	4	4	5400
3000	2x3000	9	4	4	6000
3300	2x2400 1x1800	9	4	4	6600
3600	4x1800	9	4	4	7200
4200	4x2100	13	4	4	8400
4800	4x2400	13	4	4	9600
5400	6x1800	13	4	4	10800
6000	4x3000	17	4	4	12000

Two doors sliding clear on a double line of track

Overall door width (both)	Track lengths mm	*Double Brackets	Hangers	Guides	Channel mm
2700	4x2100	7	4	4	2x4200
3000	2x2400 2x2100	7	4	4	2x4500
3300	2x3000 2x2100	8	4	4	2x5100
3600	2x3000 2x2400	8	4	4	2x5400
4200	6x2100	10	4	4	2x6300
4800	8x1800	9	4	4	2x7200
5400	4x3000 2x2100	12	4	4	2x8100
6000	10x1800	11	4	4	2x9000

Two doors sliding on double tracks between walls

Overall door width	Track lengths mm	*Brackets	Hangers	Guides	Channel mm
3000	2x3000	5	4	4	2x3000
3300	2x2400 2x900	5	4	4	2x3300
3600	4x1800	5	4	4	2x3600
4200	4x2100	7	4	4	2x4800
4800	4x2400	7	4	4	2x4800
5400	6x1800	7	4	4	2x5400
6000	4x3000	9	4	4	2x6000

*The quantities shown above include two closed end brackets.

INSTALLATION DETAILS



DOUBLE TRACK WITH TIMBER AND METAL DOORS

Face fixing open type support bracket No. 735. End brackets No. 736 left or right hand

Top fixing open type support bracket No. 748. End brackets No. 749

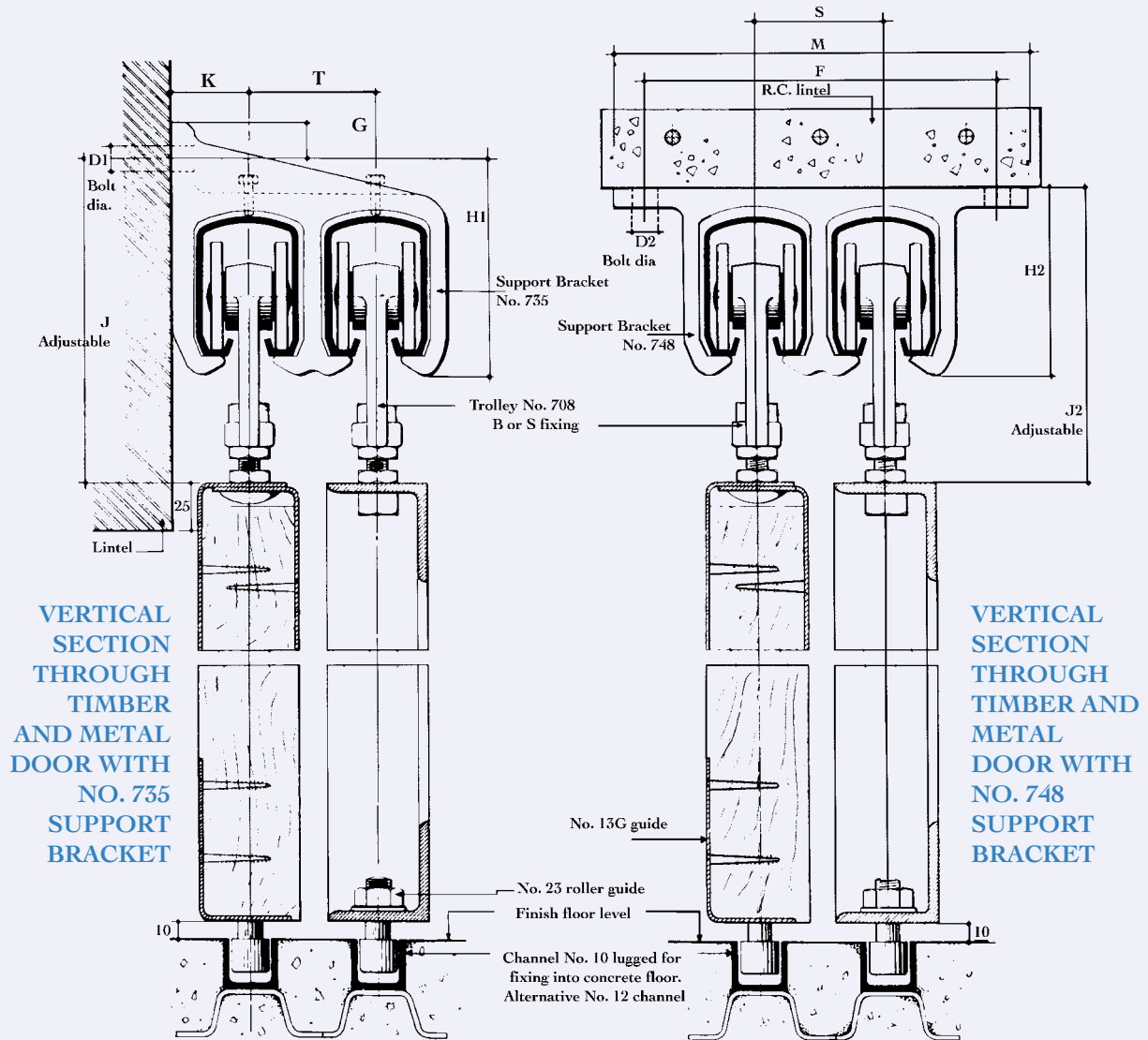

VERTICAL SECTION THROUGH TIMBER AND METAL DOOR WITH NO. 735 SUPPORT BRACKET

VERTICAL SECTION THROUGH TIMBER AND METAL DOOR WITH NO. 748 SUPPORT BRACKET

TRACK SIZE	D1	D2	F	G	H1	H2	J1 min	J1 max	J2 min	J2 Max	K	M	S	T
1	12	10	146	19	89	75	132	140	117	125	32	178	54	54
2	12	12	185	19	114	98	159	181	143	165	38	216	65	65
3	16	-	-	25	159	-	206	232	-	-	52	-	-	90
4	20	-	-	25	159	-	206	232	-	-	52	-	-	90

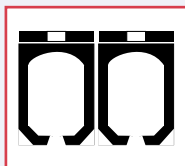

Alternative support bracket - 2 x No. 737 open parallel ear bracket top fixing

Bottom guide arrangements are interchangeable and should be selected to suit requirements and working conditions

INSTALLATION DETAILS

TRIPLE TRACKS WITH TIMBER AND METAL DOORS



Face fixing open type support bracket No. 754. End brackets No. 755 left or right hand. Size 1 & 2 only

Top fixing open type support bracket No. 737. End brackets No. 738

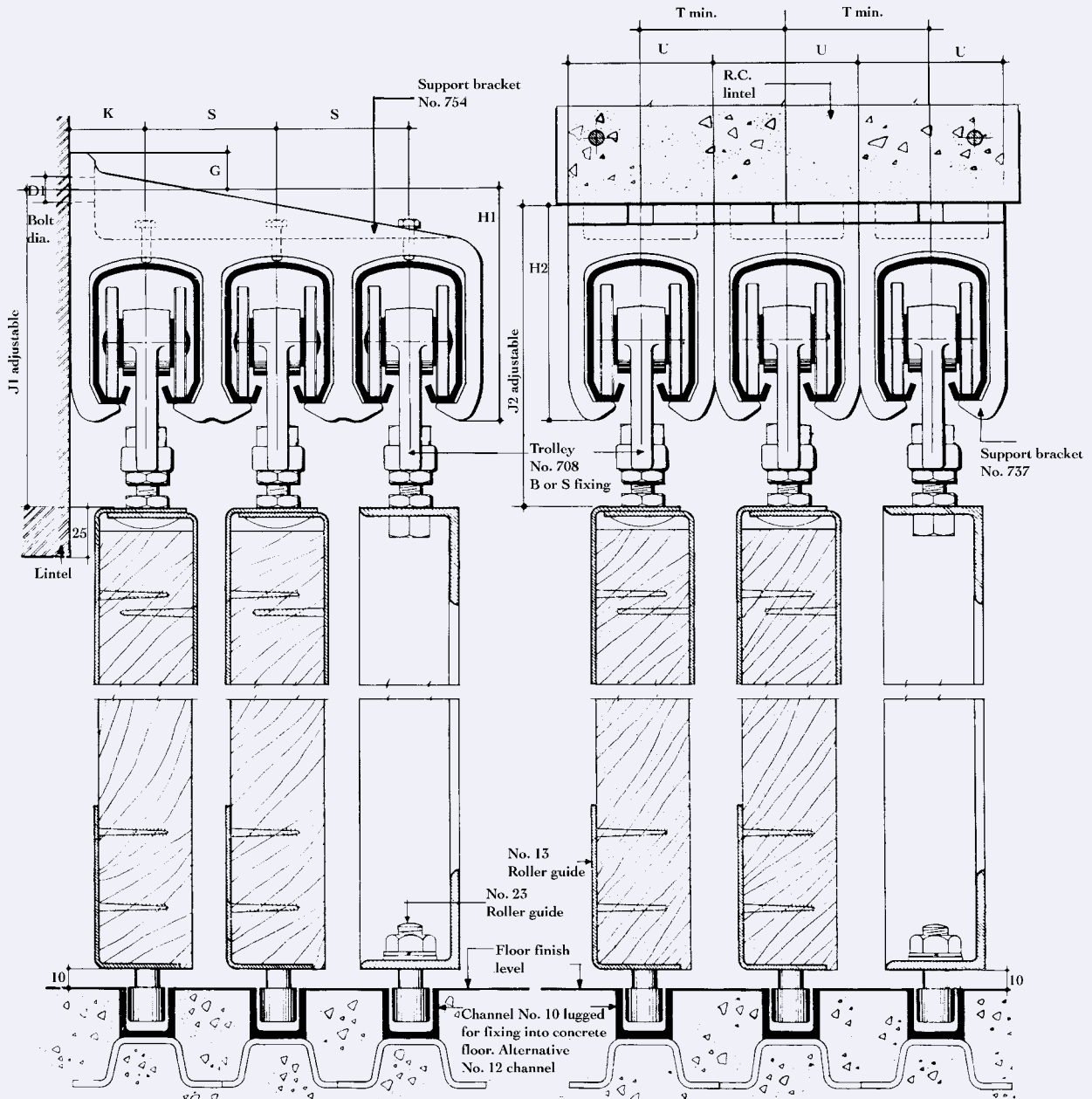

VERTICAL SECTION THROUGH TIMBER AND METAL DOOR WITH NO. 755 SUPPORT BRACKET

VERTICAL SECTION THROUGH TIMBER AND METAL DOOR WITH NO. 748 SUPPORT BRACKET

Bottom guide arrangements are interchangeable and should be selected to suit requirements and working conditions

TRACK SIZE	D	G	H1	H2	J1 min	J1 max	J2 min	J2 Max	K	S	T	U
1	12	19	89	86	130	138	129	137	32	54	57	57
2	12	19	121	111	164	186	156	178	38	68	75	75
3	-	-	-	125	-	-	176	192	-	-	89	89
4	-	-	-	149	-	-	197	222	-	-	97	97

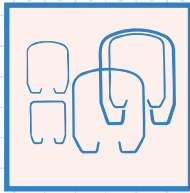

TUBULAR TRACK

KING Tubular Track is manufactured from high quality cold rolled steel strip, light coat galvanised to BS 2989. It is available in standard lengths of 1.8m, 2.1m, 2.4m, 3.0m, 4.0m, 5.0m and 6.0m (size 4 track max length 3.0m). Standard lengths can be cut to suit customers requirements before despatch, the charge being that of a standard length only.

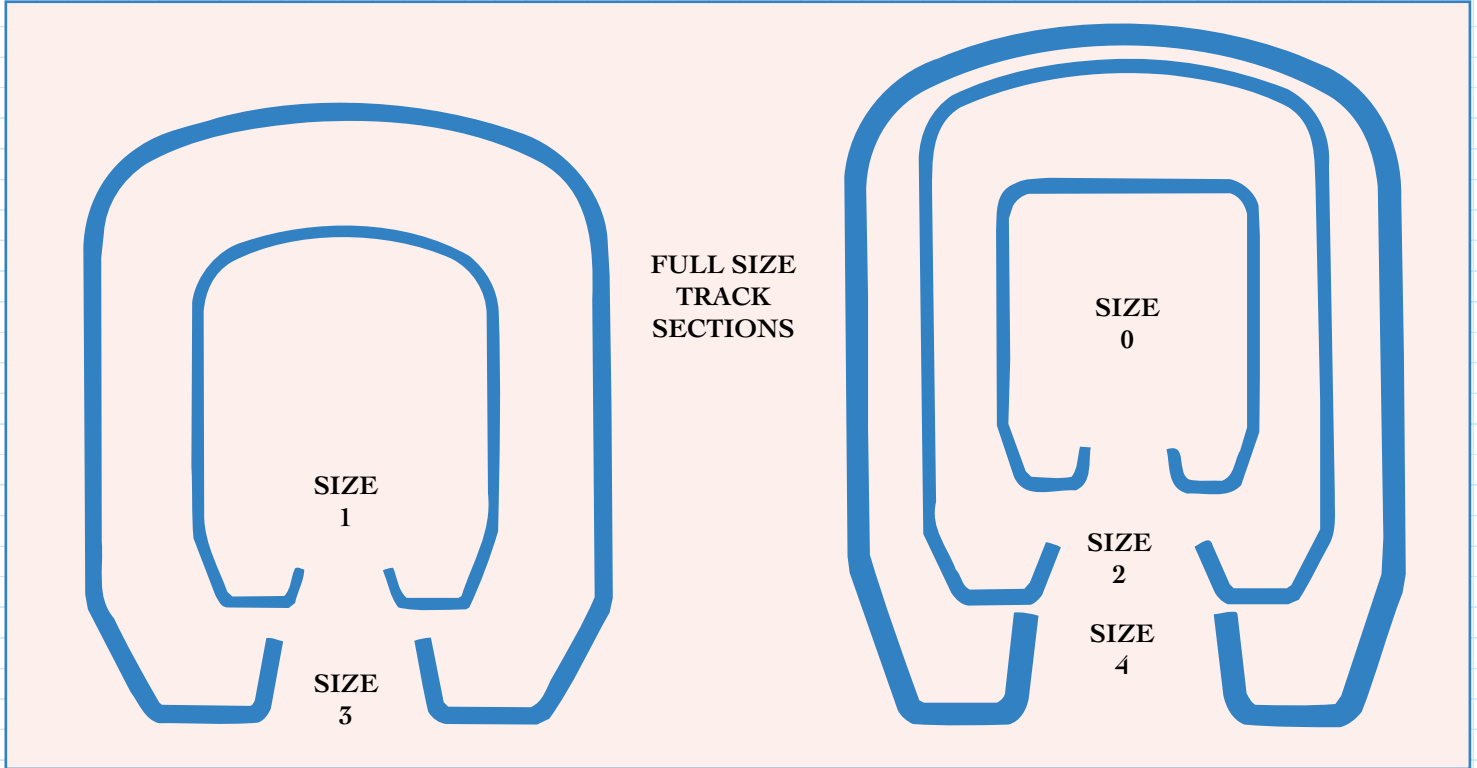

TRACK SUPPORT BRACKETS

All brackets should be spaced at regular intervals to suit track lengths, but must not exceed 914mm centres (less under arduous conditions). Closed brackets are supplied for each end of the track runs, and it is important that these are not used as door stops. It is essential that all track joints occur at the centre of the bracket.

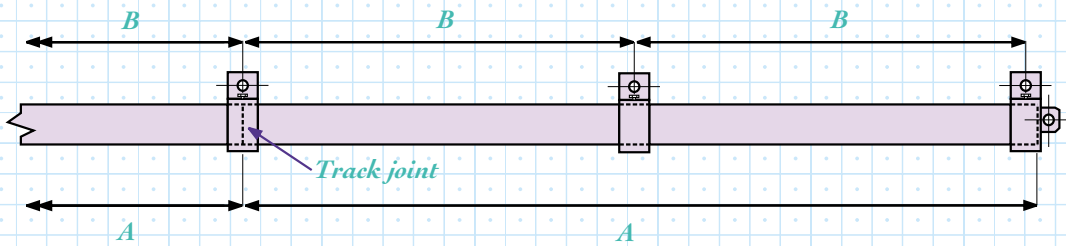

DOOR LENGTH A	1829	2134	2438	2743	3084	3657	4572
NORMAL SPACING B	914	711	813	914	762	914	914

TRACK DIMENSIONS

TRACK	GAUGE	A(mm)	B(mm)	WEIGHT PER LINEAR m.
0	16BG 1.6mm	41	36	1.65kg
1	14BG 2.0mm	51	41	2.51
2	14BG 2.0mm	73	54	3.17kg
3	12BG 2.5mm	83	70	5.30kg
4	10BG 3.0mm	94	75	7.44kg

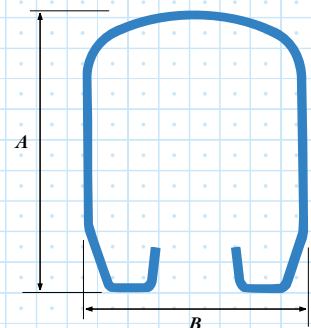

SUPPORT BRACKETS

SECTION 3 BRACKETS

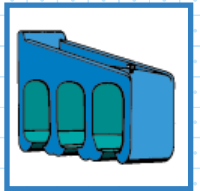

716 **717** NOS. 716/0 & 717/0(CLOSED) SIDEWALL BRACKETS

The most popular type of bracket used to support straight runs of single track length for sidewall fixing. Manufactured from high strength extruded aluminium for track sizes 0,1 and 2.

716 **717(closed)**

OPEN TYPE No. 716/0

END TYPE No. 717/0

End closer clip

TRACK	A	B	C	D	E	F	G	H	K	L	M	N
1	102	51	89	11	29	57	13	89	38	48	38	71
2	127	57	111	14	37	73	16	111	43	48	44	92
3	156	64	130	14	46	92	19	130	49	67	48	95
4	175	76	149	17	49	100	22	149	60	60	57	114

717 NOS. 716 & 717(CLOSED) SIDEWALL BRACKETS

Sidewall bracket as shown left, but manufactured in aluminium alloy for track sizes 1 and 2, and cast iron for track sizes 3 and 4.

716 **716** **717(closed)**

TRACK	A	B	C	D	E	F	G	H	K	L	M	N
1	102	51	89	11	29	57	13	89	38	48	38	71
2	127	57	111	14	37	73	16	111	43	48	44	92
3	156	64	130	14	46	92	19	130	49	67	48	95
4	175	76	149	17	49	100	22	149	60	60	57	114

735 **736** NOS. 735 & 736(CLOSED) SIDEWALL BRACKETS

Standard brackets for passing doors. Manufactured in aluminium alloy for track sizes 1 and 2, and cast iron for size 3 and 4.

735 **736(closed)**

TRACK	A	B	C	D	E	F	G	H	J	K	L	M	N
1	108	57	89	14	32	111	14	89	52	44	41	41	81
2	133	57	114	14	38	138	19	114	65	44	51	44	89
3	156	70	133	17	48	178	22	133	84	56	70	57	111
4	184	76	159	21	51	191	25	159	90	60	86	60	121

756 **756** **757(closed)** NOS. 756 & 757(CLOSED) DOUBLE OPEN BRACKETS

Basically similar to Nos. 735 and 736, but extended to accommodate thicker doors. Manufactured in aluminium alloy for track sizes 1 and 2 only.

TRACK	A	B	C	D	E	F	G	H	J	K	L	M	N
1	108	57	89	14	34	129	16	89	67	44	41	25	81
2	133	57	114	14	40	156	19	114	79	44	51	25	89

741 NOS. 741/0 & 742/0(CLOSED) SIDE EAR BRACKETS

Designed for soffit fixing. Adjustable bright zinc plated pressed steel mounting bracket with heavy duty extruded aluminium track carrier for size 0 track only. Particularly suitable for interior folding partitions, where a neat installation is desirable.

741/0 **742/0(closed)**

End closer

TRACK	A	B	D	F	G	H	K	M	N	P
1	86	51	11	56	76	102	38	44	60	8
2	111	57	11	71	92	114	43	51	71	10
3	125	64	14	87	106	143	49	57	82	10
4	149	76	17	94	121	162	60	70	95	11

737 NOS. 737 & 738(CLOSED) PARALLEL EAR BRACKETS

These brackets are manufactured in aluminium alloy for track sizes 1 and 2, and cast iron for track sizes 3 and 4.

737 **738(closed)**

TRACK	A	B	D	F	G	H	K	M	N	P
1	86	51	11	56	76	102	38	44	60	8
2	111	57	11	71	92	114	43	51	71	10
3	125	64	14	87	106	143	49	57	82	10
4	149	76	17	94	121	162	60	70	95	11

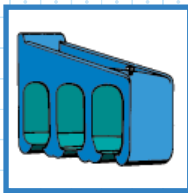

737S

NOS. 737S & 738S(CLOSED) PARALLEL EAR BRACKETS

Designed for use with Tubular Track Runways, but may be used for doors as an alternative to Nos. 737 and 738 closed end (Note dimensional variations). One side of the open type bracket is detachable to permit speedy installation of the track. Manufactured in pressed steel with painted finish for track sizes 1 and 2 only.

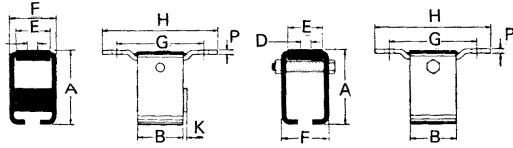

738S(closed)

737S

TRACK	A	B	D	E	F	G	H	K	P
1	81	51	11	38	51	95	127	5	5
2	102	51	11	38	64	95	127	5	5

741



742

NOS. 741 & 742(CLOSED) SIDE EAR BRACKETS

These brackets are similar in design to 741/0 and 742/0, but are manufactured in aluminium alloy for track sizes 1 and 2, and cast iron for track sizes 3 and 4.

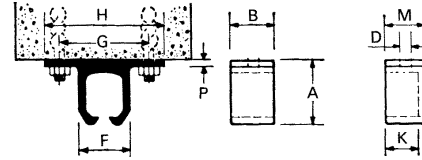

741

742(closed)

TRACK	A	B	D	F	G	H	K	M	P
1	75	51	11	56	102	137	44	51	8
2	98	57	11	56	108	143	44	51	10
3	111	64	14	88	127	187	49	57	13
4	124	76	17	97	152	195	60	70	16

739

740



NOS. 739 & 740(CLOSED) FASCIA BRACKETS

Recommended for use where there is insufficient headroom to accommodate the Nos. 716 and 717 brackets. Manufactured in aluminium alloy for track sizes 1 and 2.

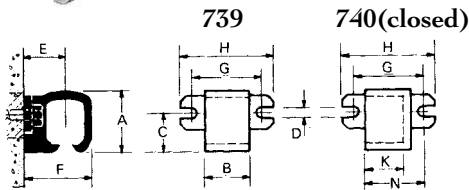

739

740(closed)

TRACK	A	B	C	D	E	F	G	H	K	N
1	68	51	44	11	44	71	76	102	38	60
2	94	57	57	14	55	92	87	114	43	71



743

NOS. 743 & 744(CLOSED) PARALLEL EAR BRACKETS

Alternatives to 737 and 738, these brackets are designed to fit to the underside of rolled steel joists. Manufactured in aluminium alloy for track sizes 1 and 2 only.

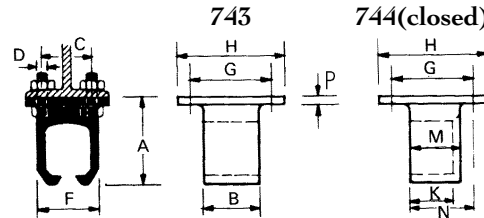

743

744(closed)

TRACK	A	B	C	D	F	G	H	K	M	N	P	Q
1	86	51	48	11	56	89	121	38	44	67	8	89
2	111	57	54	11	74	102	133	44	51	76	10	102

748



NOS. 748 & 749(CLOSED) DOUBLE SIDE EAR BRACKETS

These brackets are designed to support double runs of track fixed to the underside of a lintel. Particularly useful for installations of passing doors within an opening. Manufactured in aluminium alloy for track sizes 1 and 2 only.



748

748

749(closed)

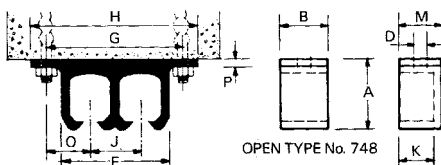

TRACK	A	B	D	F	G	H	J	K	M	O	P
1	75	51	11	110	146	178	53	44	51	46	10
2	98	57	14	141	183	216	67	44	51	57	10



754

NOS. 754 & 755(CLOSED) TRIPLE SIDEWALL BRACKETS

Designed to support treble runs of track. Manufactured in aluminium alloy or cast iron for track sizes 1 and 2 only.

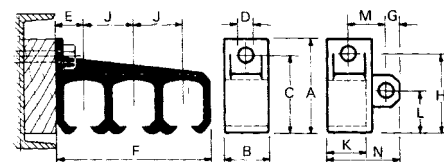

754

755(closed)

TRACK	A	B	C	D	E	F	G	H	J	K	L	M	N
1	108	57	89	14	34	161	14	89	52	44	48	41	81
2	140	57	121	14	38	210	19	102	68	44	57	49	89



DOOR HANGERS

SECTION 4 HANGERS

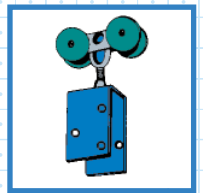

HANGERS FOR SIZES 0,1,2 and 3 TUBULAR TRACK

Hangers for size 0 track are fitted with a Delrin body and nylon wheels, sizes 1,2 and 3 hangers have steel bodies fitted with nylon wheels as standard, steel wheels optional extra.

NO. 709B/0 HANGER

This hanger is specially designed for timber doors of varying thickness. Vertical adjustment is obtained by means of a special adjusting nut on the hanger pendant, and lateral adjustment is achieved by slotted holes in the fixing plates. Both adjustments can easily be made after the door has been hung.



TRACK SIZES 0,1,2 AND 3

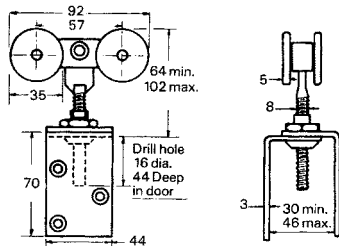

NO. 709S/0 HANGER

A hanger specifically for use with metal framed doors. Vertical adjustment is easily achieved by adjuster nuts on the hanger pendant, while provision for lateral adjustment must be made by means of a slotted hole in the door frame.



TRACK SIZES 0,1,2 AND 3

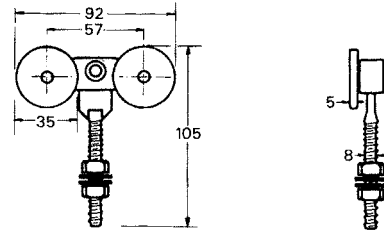

HANGERS FOR SIZES 1,2,3 and 4 TUBULAR TRACK

The four-wheel hangers for sizes 1,2 and 3 TUBULAR TRACK have malleable iron bodies fitted with nylon wheels and ball-bearing races, which are grease packed for life. Size 4 hangers are of similar construction, but have steel wheels with machined treads. Pendant bolts are of bright zinc plated steel, hanger plates are of pressed steel. Sizes 1 and 2 being galvanised and sizes 3 and 4 aluminium painted. The use of nylon wheels running in galvanised steel track ensures extremely quiet operation in addition to prolonging the track life.

NO. 708B HANGER

The above hanger is also designed for use with timber doors, and is available for all track sizes. The double strap fixing plates provide vertical and lateral adjustment after the door is hung. No cutting of the door is necessary.

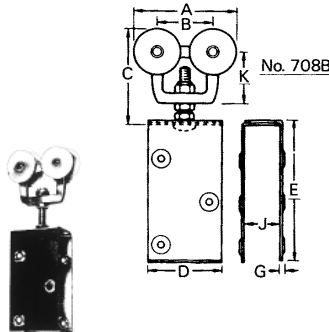

TRACK	A	B	C		D	E	G	K	J	bolt dia.
	max	min	max	min						
1	102	60	108	90	51	165	6	51	48	12
2	127	70	146	119	51	165	6	65	48	12
3	149	83	159	159	64	229	8	76	59	12

NO. 708D HANGER

A hanger which gives an extremely neat appearance for interior work and, if the track and brackets are enclosed, no fittings are visible. It is available for track sizes 1, 2 and 3 only and the hanger plate is constructed of aluminium painted steel. Vertical adjustment is obtained as with previous timber door hangers.

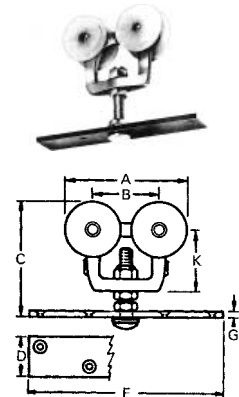

TRACK	A	B	C		D	F	G	H	K	bolt dia.
	max	min	max	min						
1	102	60	108	90	38	203	6	102	51	12
2	127	70	146	119	38	203	6	102	65	12
3	149	83	159	155	81	229	8	114	76	12

NO. 708E HANGER

This hanger is used similarly to the No. 708D above but provides a stronger fixing. If the track and brackets are enclosed, the only parts visible are the vertical straps on the edges of the door. The hanger plate is constructed of aluminium painted steel. Vertical adjustment is obtained as with previous timber door hangers.

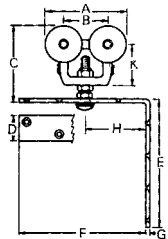

TRACK	A	B	C		D	E	F	G	H	K	bolt dia.
	max	min	max	min							
1	102	60	108	90	38	203	203	6	96	51	12
2	127	70	146	119	38	203	203	6	95	66	12
3	149	83	159	135	44	222	222	8	111	76	12
4	159	83	181	152	51	241	241	10	121	76	16

NO. 708S HANGER

This hanger is designed specifically for use with metal framed doors. Vertical adjustment is easily achieved after the door has been hung, but provision must be made for lateral adjustment by means of a slotted hole in the door frame. Special pendants can be supplied on request in lengths of 114mm or 178mm for increased vertical adjustment.

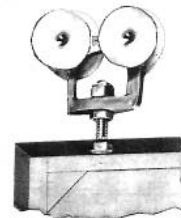

TRACK	A	B	C		K	bolt dia.
	max	min	max	min		
1	102	60	108	90	51	12
2	127	70	146	119	66	12
3	149	83	159	135	76	12
4	159	83	181	152	76	16



NO. 6 GUIDE

The standard floor fixing roller guide, used where channel and guides are undesirable, e.g. agricultural buildings. Consists of a nylon roller mounted on a zinc plated spindle ragged for concrete.

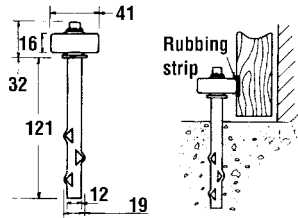

NO. 6H GUIDE

A heavy duty version of the No. 6, it comprises a cast iron roller mounted on a steel spindle ragged for concrete, finished in 'aluminium' paint.

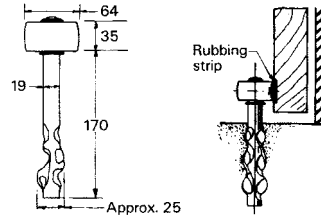

NO. 7 GUIDE

A wall fixing guide designed for use where floor channel and No. 6 guides are undesirable. It comprises a nylon roller on a steel bracket finished in 'aluminium' paint.

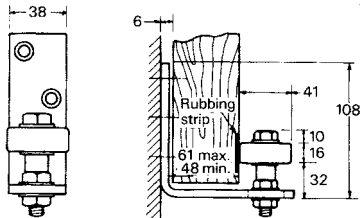

NO. 7H GUIDE

A heavy duty version of the No. 7 guide comprising a cast iron roller mounted on a steel bracket finishes in 'aluminium' paint.

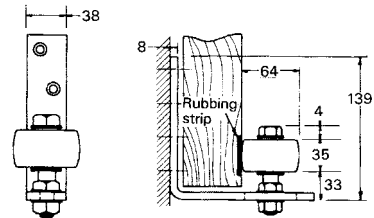

NO. 8 GUIDE

Intended as an alternative to the No. 6H guide, the No. 8 consists of a cast iron roller mounted on a steel bracket. Painted finish.

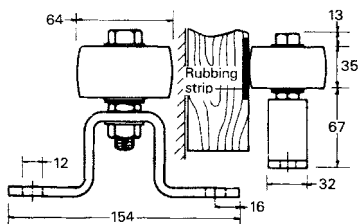

NO. 9 GUIDE

A vertically adjustable bottom guide consisting of a nylon body and machined steel spindle with brass roller. Used in conjunction with No. 6 Floor Channel on timber doors not exceeding 22 Kg (50 lb) leafweight.

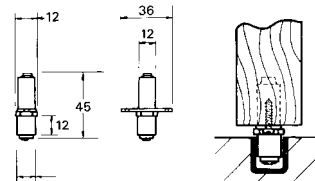

NO. 11G GUIDE

Designed to fit flush to the underside of timber doors. Zinc plated steel plate and spindle with nylon roller. For use with Nos. 10 & 12 Channels. Also available with a brass roller (not illustrated), specify No 11GB.

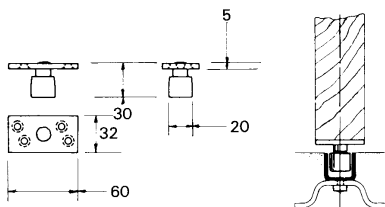

NO. 13G GUIDE

Standard angle strap roller guide for general purpose use. Easily installed or replaced without dismantling doors. Rustproofed steel strap with steel spindle and nylon roller. Use with No. 10 or 12 Channels. Available with brass roller (not illustrated) specify 13GB.

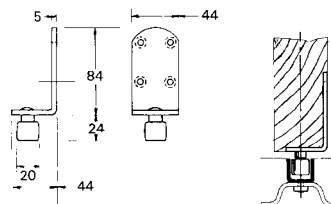

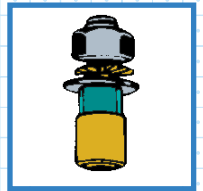

NO. 13H GUIDE

Heavy duty version of No 13G but for use with No. 14 Channel. Comprising steel strap and spindle with heavy brass roller. Painted finish.

NO. 15G GUIDE

Stirrup strap bottom roller guide for use with timber doors 2", 2 1/4", and 2 1/2" thick. Comprising steel strap and spindle with nylon roller. Painted finish. For use with No. 10 and 12 Channels. Available with brass roller (not illustrated) specify 15GB N.B. Always specify door thickness.

NO. 19 GUIDE

Heavy pattern solid shoe guide for use with Nos. 10 or 12 Channels. In malleable iron, painted finish.

NO. 22 GUIDE

Intended for light metal doors. Use with No. 6 Channel. Steel spindle with brass roller.

NO. 25 GUIDE

Standard roller guide for metal doors, used with either No. 10 or 12 Channel. Rustproofed steel spindles with nylon roller. Available with brass roller (not shown) specify No. 25B. No. 24 as No. 25 but with long spindle for R.H.S. Steel framed doors. No. 24B as No. 24 but with brass roller.

NO. 25H GUIDE

A heavy duty version of No. 25 for use with No. 14 Channel only. Rustproofed steel spindle with brass roller.

NO. 39 GUIDE RAIL

Steel bulb-tee guide rail for use with No. 8 Channel inverted, and recommended for arduous conditions. This method has the added advantage of being virtually draught and vermin proof.



SECTION 6
CHANNEL



NO. 6A CHANNEL

An aluminium channel supplied in natural finish for use with Nos. 9 and 22 roller guides. Intended for interior work and available either plain, or drilled and countersunk in 1.52 m and 3.04 lengths.

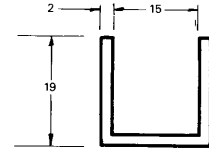

NO. 8 CHANNEL

A rolled mild steel channel for use with No. 39 bulb-tee guide rail, and recessed into the base of timber doors. Available in standard lengths of 1.83m, 2.13m, 2.44m, 2.74m and 3.04 m, either plain or drilled and countersunk.

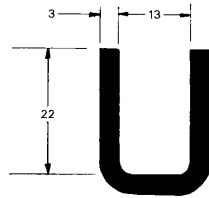

NO. 10 CHANNEL

The standard steel channel for use with most roller guides. Available either plain, drilled and countersunk, or lugged for setting in concrete in standard lengths of 1.83m, 2.13m, 2.74m and 3.04m.

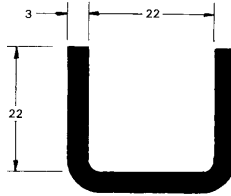

NO. 12 CHANNEL

As No. 10 above but of a deeper section to minimise clogging. Available either plain, drilled and countersunk, or lugged for setting in concrete in standard lengths of 1.83m, 2.13m, 2.44m, 2.74m and 3.04m.

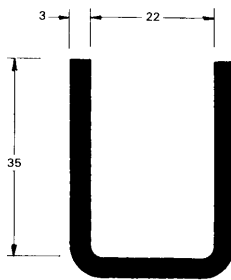

NO. 14 CHANNEL

A rolled mild steel channel for use with heavy duty roller guides. Available in standard lengths of 1.83m, 2.13m, 2.44m, 2.74m and 3.04m, either plain, drilled and countersunk or lugged for setting in concrete.

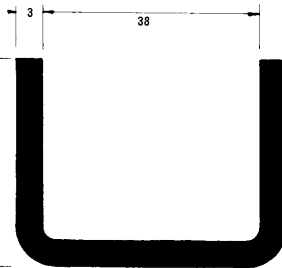

NO. 759 CHANNEL SUMP BOX

The use of a channel sump box is strongly recommended in conjunction with Nos. 10, 12 and 14 channels, to prevent water standing in the channel. The occasional cleaning out of the sump box also assists in increasing the life of the channel. It is recommended that a soak-away pit be made under the sump box. The box is constructed of cast iron, complete with lid.

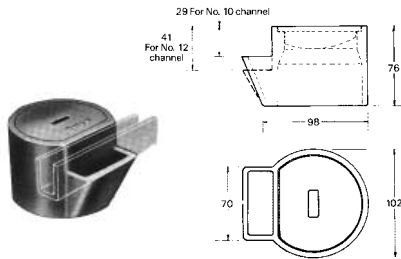

CHANNEL LUGS

Channel lugs manufactured from pressed mild steel are supplied with Nos. 6S, 8, 10 and 12 channels on request. (Supplied flat)

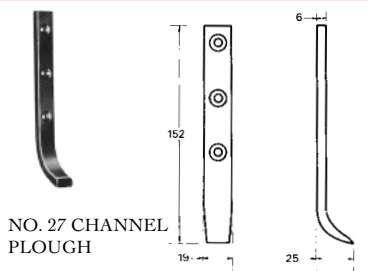
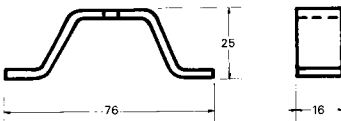

NO. 27 CHANNEL PLOUGH

Channel ploughs fitted to the leading edge of the door are recommended to keep Nos. 10 and 12 channels clear of obstruction.

WEATHER HOOD

The use of King weatherhood is strongly recommended for all exterior applications to protect the gear and enhance the weather sealing of the installation. King weatherhood is constructed of pressed steel galvanised to BS2989. It is available in standard lengths of 0.91m, 1.22m, 1.52m and 1.83m (3ft, 4ft, 5ft and 6ft) for single or double track, sizes 1, 2, 3 and 4.

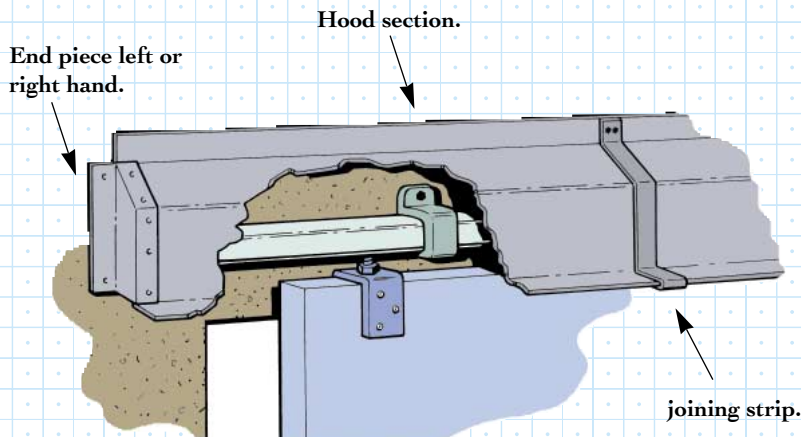

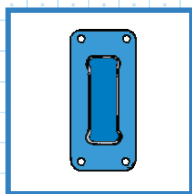

NO. 4521 MALLEABLE IRON BOW HANDLE

165mm overall. 114mm grip.



NO. D111 HEAVY MALLEABLE IRON BOW HANDLE

229mm overall x 19mm dia. 140mm grip.



NO. 73 malleable iron flush handle

Available in two sizes :
111 x 85 x 29mm deep and
162 x 111 x 38mm deep.



NO. 770 ALUMINIUM FLUSH HANDLE

140mm x 64mm x 22mm deep.



NO. 8049 MALLEABLE IRON FLUSH BOLT

305mm x 51mm with 25mm x 10mm flat shoot, 35mm throw.



NO. 8051 DROP BOLT

457mm steel bolt with malleable fittings.



NO. 215 HASP & STAPLE

203mm x 44mm overall. Malleable iron, art black finish.



NO. 919 CRANKED LOCKING BAR

With falling staple, 305mm overall.



NO. 1515 MALLEABLE IRON LOCKING BAR

Art black finish with swivel bar which falls into vertical position when not in use. Available in two sizes 305mm and 457mm.



NO. WS1 WALL FIXING DOOR STOP

For single track runs comprising: rubber buffers mounted on a steel bracket.



NO. FS2 FLOOR FIXING DOOR STOP

For double track runs comprising: four rubber buffers on a steel bracket.



NO. FS1 FLOOR FIXING DOOR STOP

For single track runs comprising: steel bracket with rubber buffers.



NO. 773 MALLEABLE IRON CENTRE STOP

For use with track sizes 1 and 2. Face fixing only.



COMPACT HIGH PERFORMANCE

• ALL STEEL • BALL BEARING • SELF ALIGNING • GALVANIZED •

TRACKS

2.5mm extra thick structural quality galvanised steel to BS 2989 with flat tread for strength and durability. Available in 2 and 3 metre lengths.

BRACKETS

High strength precision pressed steel zinc plated. Single and double sidewall brackets and soffit brackets. brackets designed for 1 metre spacing, with intermediate brackets introduced when nearing maximum loading, exposed conditions or heavy usage.

HANGERS

Pressed steel body with self aligning independent steel ball bearing wheels to ensure equal weight distribution. All steel part electro zinc plated. Hangers for timber doors supplied with adjustable aprons.

GUIDES, CHANNEL AND FURNITURE

These items are interchangeable and can be selected from the items in the previous sections to suit the application.



Track size	Sidewall brackets	Steel door hangers	Timber door hangers	Double sidewall brackets	Soffit brackets
200	1/200	200ES	200E	5/200	2/200
400	1/400	400ES	400E	5/400	2/400
600	1/600	600ES	600E	5/600	2/600

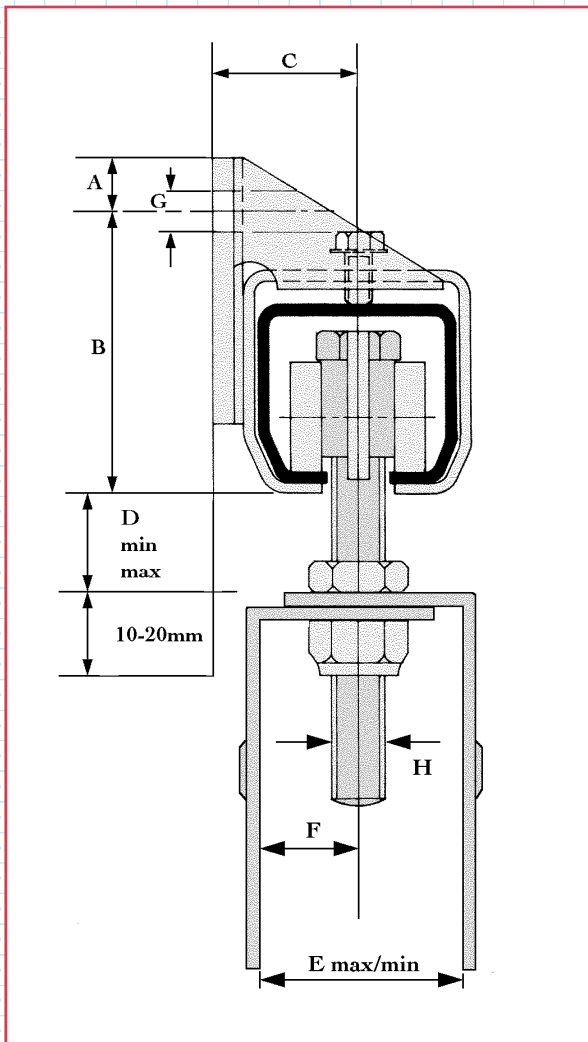

TRACK SIZE	200	400	600
A	10	12	14
B	55	64	88
C	27	33	38
Dmin timber	21	24	24
Dmax timber	45	74	65
Dmin steel	11	11	11
Dmax steel	27	54	42
E min	38	48	48
E max	48	57	64
F	21	21	25
G	8	10	12
H	10	12	14

EUROGEAR is also available in kit form. Four kits cover single and double doors up to 3m wide x 4m high and up to 400 kg per leaf. Kits are boxed for easy storage and transport.

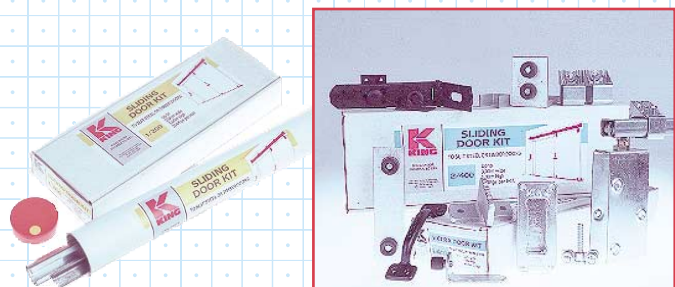

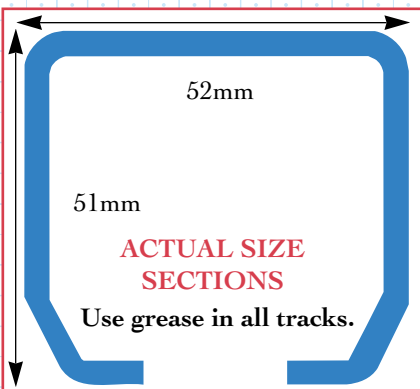

ACTUAL SIZE SECTIONS

Use grease in all tracks.

TRACK 600

CAPACITY 600KG
DOORS UP TO 4.8M

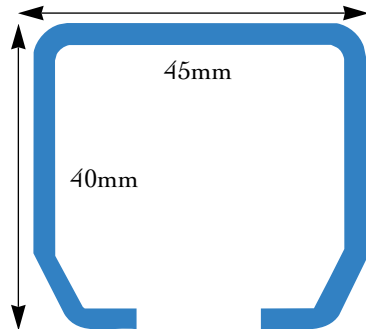

TRACK 400

CAPACITY 400KG
DOORS UP TO 4.2M

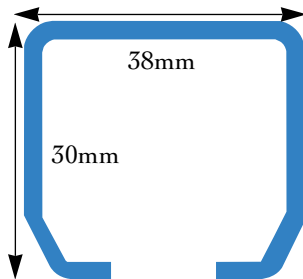

TRACK 200

CAPACITY 200KG
DOORS UP TO 3.3M

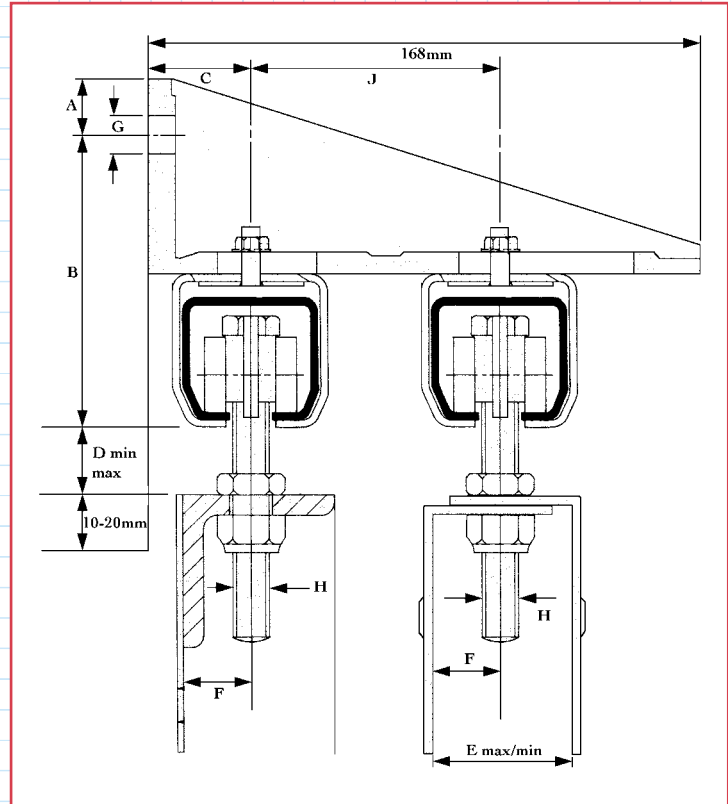

TRACK SIZE	200	400	600
A	21	21	21
B	83	93	108
C	27	33	38
Dmin timber	21	24	24
Dmax timber	45	74	65
Dmin steel	11	11	11
Dmax steel	27	54	42
E min	38	48	48
E max	48	57	64
F	21	21	25
G	16	16	16
H	10	12	14
Jmin timber	E + 18	E + 18	E + 18
Jmax timber	105	100	95
Jmin steel	E + 12	E + 12	E + 12
Jmax steel	105	100	95

NB. minimum dimension J is based on doors with flush door handles and fittings. In the case of steel frame doors make allowance for bolt head when fixing facing sheets/panels.



Compact performance

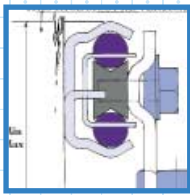

FOR STRAIGHT SLIDING INTERIOR DOORS UP TO 68kg PER LEAF

ROYALE is designed to provide an exceptionally smooth, quiet and effortless movement. Vertical and lateral adjustment of the door is easily obtained after fixing. The bottom guide system permits a completely clear threshold.

TRACK. Smooth, high grade galvanised steel with prepared fixing holes.

CARRIAGE. The carriage unit is of highly engineered galvanised pressed steel with steel ball bearings for smooth operation and long life.

SUSPENSION. The door is suspended from the carriage unit by two pendant bolts and plates incorporating vertical and lateral adjustment.

BOTTOM GUIDE SYSTEM. Galvanised steel channel recessed into the underside of the door and engaged with a nylon floor guide at one side of the opening allows smooth operation and a clear threshold.

DOOR STOP. Rubber buffer mounted on steel bracket.

PELMET. One piece pressed-steel construction, finished with one coat of grey primer.

Set complete with easy to follow instructions.

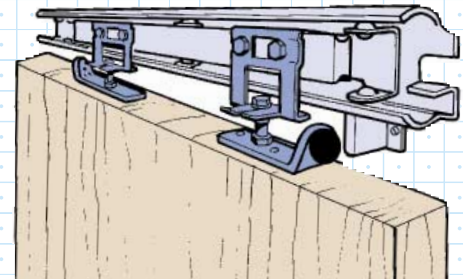

**68kg
Max.**



Often used for domestic applications, Royale is however, sufficiently robust for commercial applications as shown above.

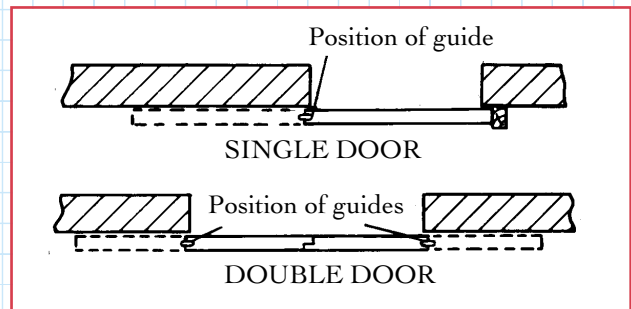
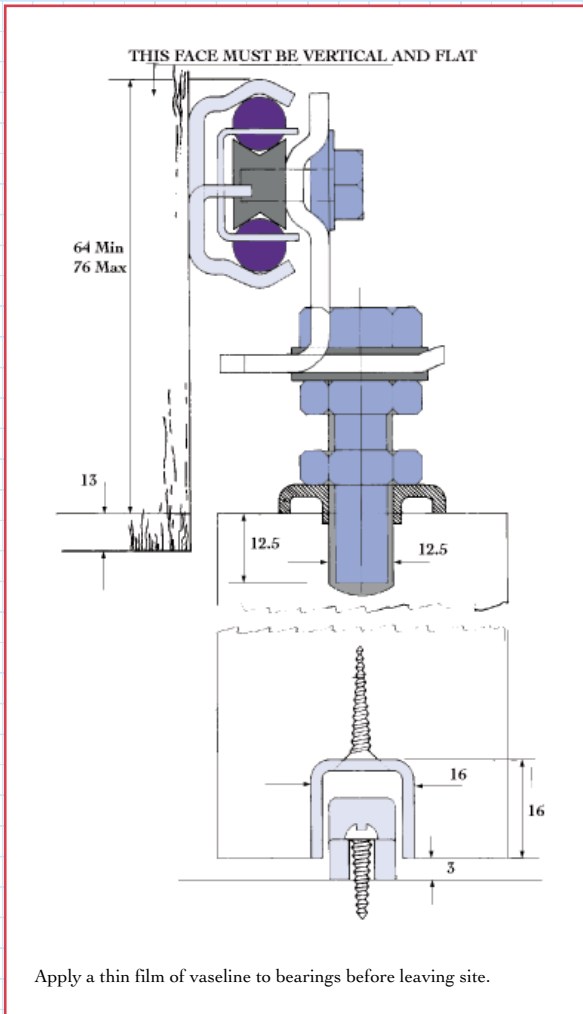

SET NUMBER	Capacity per leaf	Track length	Centres of hangers	Max. door width	Min. door thickness
KJ3	68kg	825	305	836	25
KJ4	68kg	1040	445	836 - 1067	25

Standard sets are designed to mount one door only. Where bi-parting doors are required, two standard sets should be used.

K KING

KING SUPPLY AN EXTENSIVE RANGE OF DOOR GEAR COMPONENTS TO SUIT ALL SLIDING APPLICATIONS. FOR COMPLETE DOOR SYSTEMS OR SPARE PARTS, KING CARRY EXTENSIVE STOCKS.

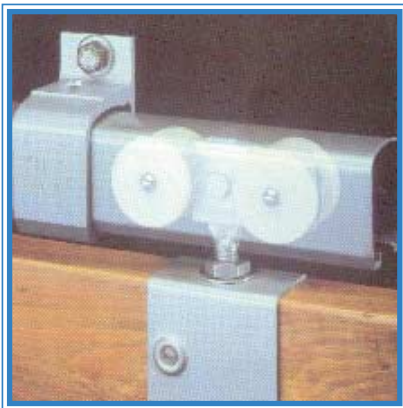

SLIDING DOOR GEAR



FOLDING DOOR GEAR
(END HUNG)



FOLDING PARTITION
DOOR GEAR



SLIDE ASIDE

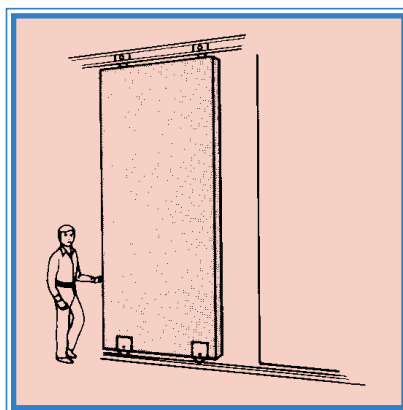

ROLLAWAY (BOTTOM
ROLLING)

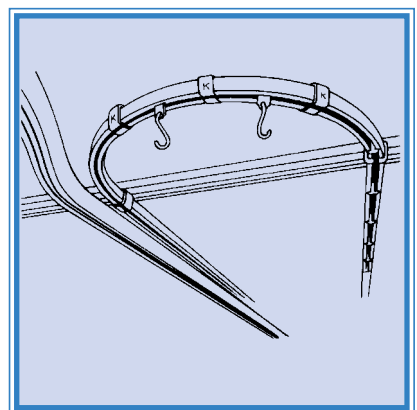

OVERHEAD RUNWAY
SYSTEMS

CONTACT OUR SALES TEAM FOR MORE DETAILS

BIS DOOR SYSTEMS LTD

PO Box 1, Wickford, Essex, SS11 8XR

T: 01268 767566 F: 01268 560284